

8800 CPU BOARD ASSEMBLY

Integrated Circuit Installation

There are 18 integrated circuits (IC's) to be installed on the 8800 CPU Board. One of these, the 8080 CPU IC, will be provided with a 40-pin IC socket. The 8080 IC itself should not be installed into the socket until the entire board is ready to be installed in the 8800.

- () Referring to the component layout, set the 40-pin IC socket included in your kit into place, and secure it with a piece of masking tape. (see drawing below)

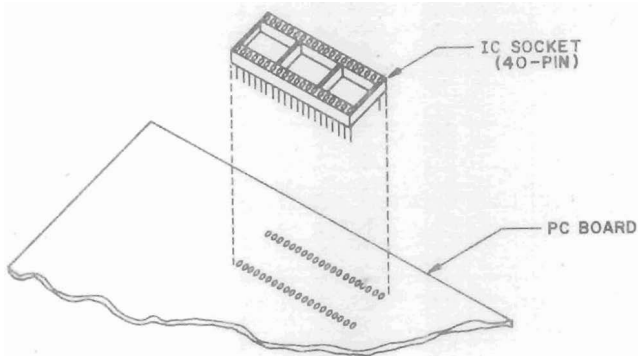

- () Turn the board over and solder each pin to the foil pattern on the back side of the board. Be sure to solder each pin and be careful not to leave any solder bridges.
- () Turn the board over again and remove the masking tape.
- () Referring to the component layout, remove the IC with the correct part number from its holder. If there are any bent pins, straighten these using needle-nose pliers. Ensure that you choose the IC with the correct part number as you install each one.

- () Orient the IC so that its notched end corresponds with the notch printed on the PC board, and pin 1 of the IC corresponds with the pad marked with an arrowhead on the board.

NOTE: If the IC does not have a notch on one end, refer to the IC Orientation Chart included with your manual for the identification of pin 1.

- () When you have the correct orientation, start the pins on one side of the IC into their respective holes on the silk-screened side of the PC board. **DO NOT PUSH THE PINS IN ALL THE WAY.** If you have difficulty getting the pins into the holes, use the tip of a small screwdriver to guide them.
- () Start the pins on the other side of the IC into their holes in the same manner. When all of the pins have been started, set the IC in place by gently rocking it back and forth until it rests as close as possible to the board. Make sure that the IC is perfectly straight and as close as possible to the board; then tape it in place with a piece of masking tape.
- () Turn the board over and solder each pin to the foil pattern on the back side of the board. Be sure to solder each pin and be careful not to leave any solder bridges.
- () Turn the board over again and remove the piece of masking tape.

--
Use the same procedure to install each of the IC's. Be sure that you have the correct part number and the correct orientation as you install each one.

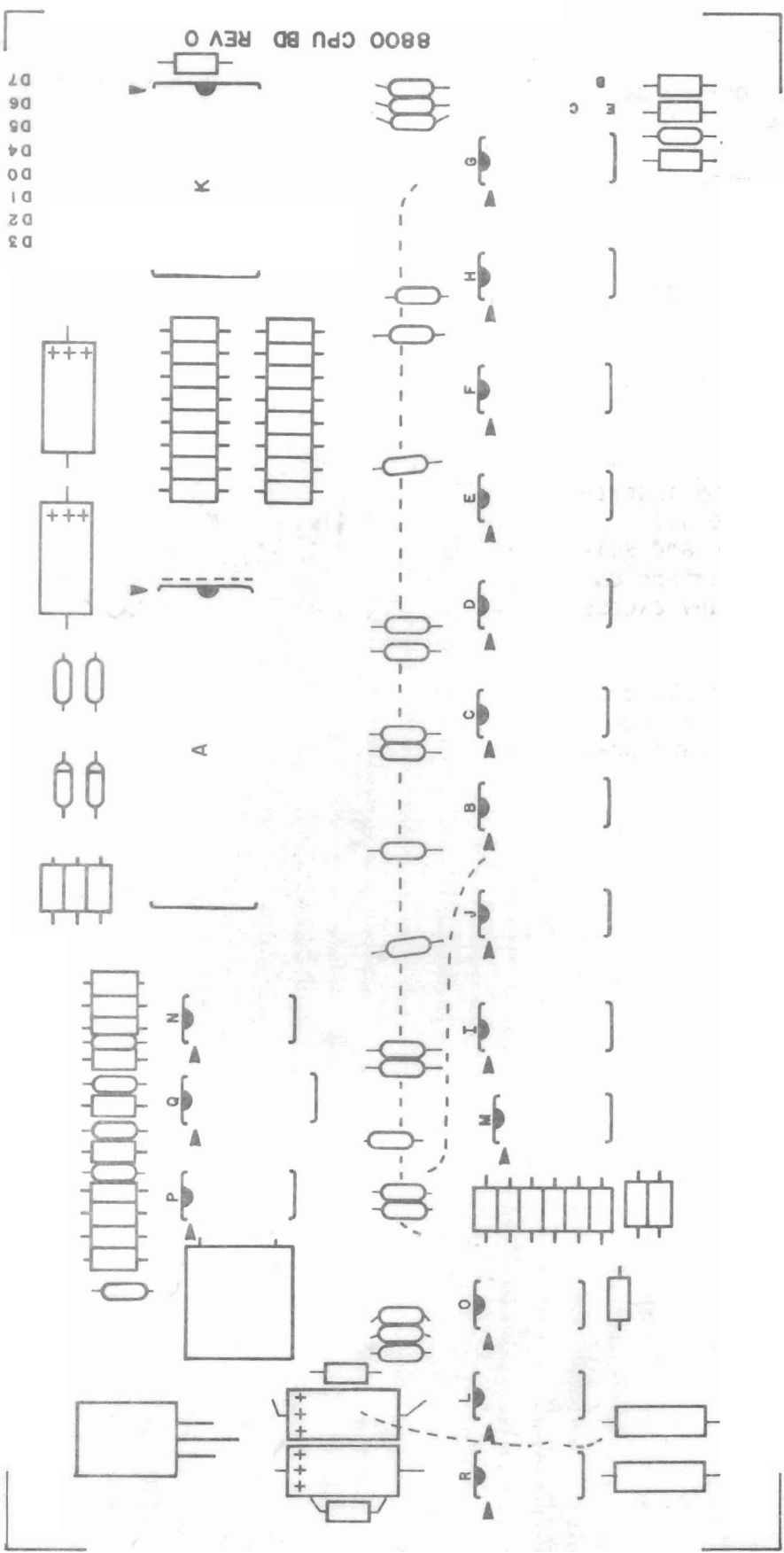

- Install a 40-pin socket in IC A position.
- K is an 8212
- P is a 7404
- Q is a 74123
- N is a 7406

- R is a 74L00
- L is a 74L74
- O is a 74L02
- M is a 74LS04
- I, J, B, C, D, E, F, H, and G are 8T97's

Hardwire Jumper Connections

There are 5 jumper connections to be made on the 8800 CPU Board.

All of the jumper connections on this board are to be made in the same manner. These connections are indicated on the board by two pads marked with the same designation and connected by a broken line. (i.e., J1-----J1)

Use the wire provided in your kit for jumper connections and cut each one to length as needed.

- () Connect pad J1 to pad J1 by inserting the wire ends from the silk-screened side of the board and soldering them to the foil pattern on the back side. Clip off any excess lead lengths.
- () Connect J2 to J2 and J3 to J3, etc., in the same manner. Be sure you connect the pads with the same designation each time.

() Install jumpers J1 through J5

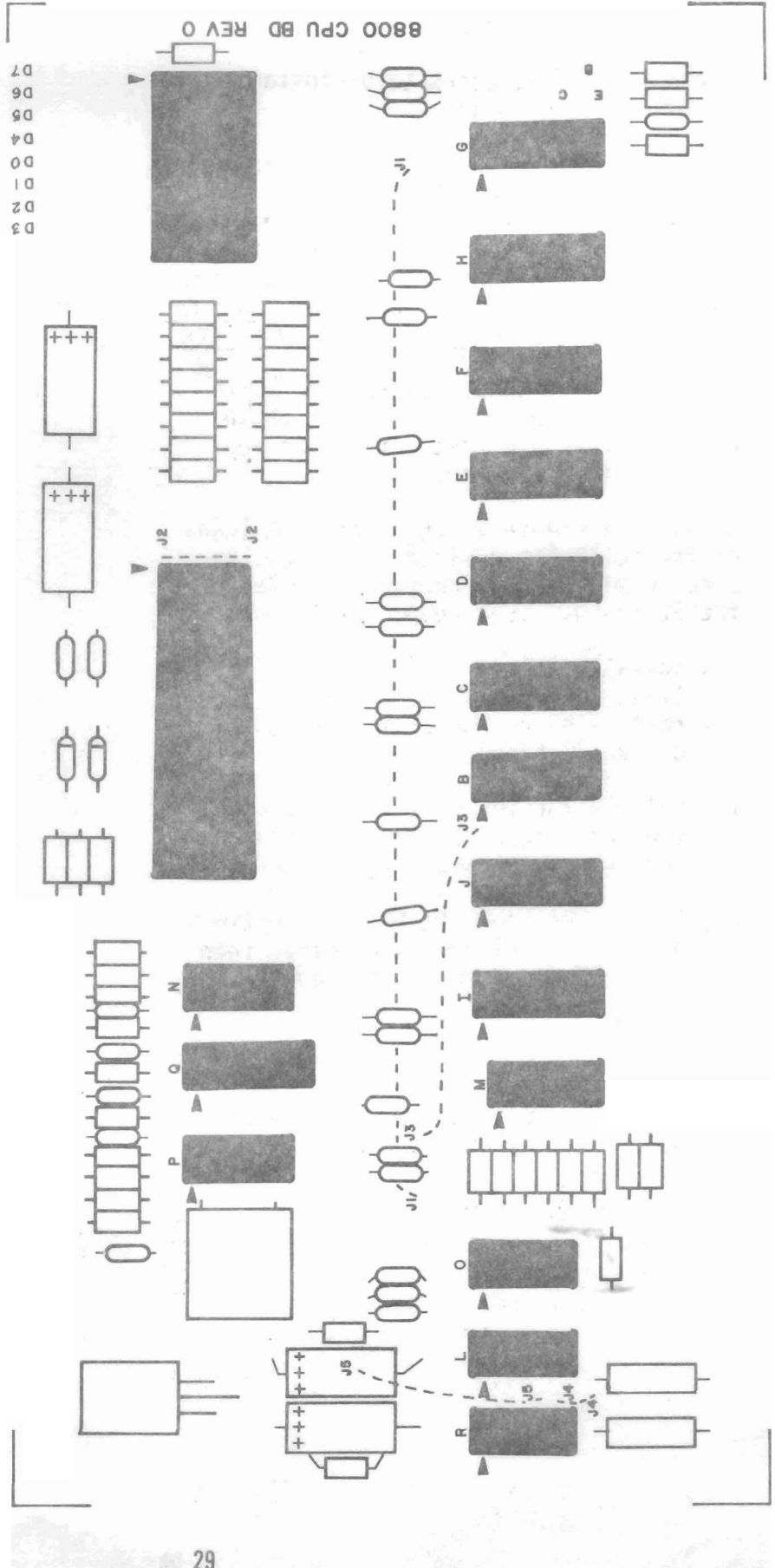

Capacitor Installation

There are 28 ceramic disk and 4 electrolytic capacitors to be installed on the 8800 CPU Board.

Refer to the component layout and install the ceramic disk capacitors according to the following procedure.

- () Choose the capacitor with the correct value as called for in the instructions. Straighten the two leads and bend them as necessary to fit their respective holes on the PC board.
- () Insert the capacitor into the correct holes from the silk-screened side of the board. **Push the capacitor** down until the ceramic insulation almost touches the foil pattern.
- () Holding the capacitor in place, turn the board over and bend the two leads slightly outward.
- () Solder the two leads to the foil pattern on the back side of the board; then clip off any excess lead lengths.

Install all of the ceramic disk capacitors in this manner. Be sure that you have the correct value capacitor as you install each one.

The four electrolytic capacitors for the CPU Board have polarity requirements which must be noted before installation. Those contained in your kit may have one or possibly two of three types of polarity markings. To determine the correct orientation, look for the following: (see drawing above right)

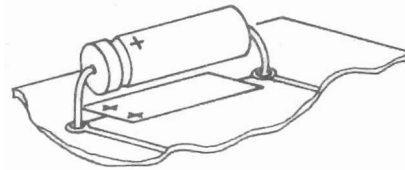

ELECTROLYTIC
CAPACITOR

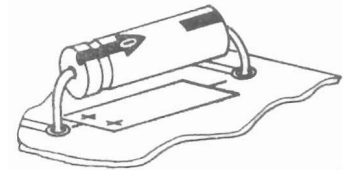

One type will have plus (+) signs on the positive end; another will have a band or a groove around the positive side in addition to the plus signs. The third type will have an arrow on it; in the tip of the arrow there is a negative (-) sign and the capacitor must be oriented so the arrow points to the negative polarity side.

Referring to the component layout, install the electrolytic capacitors on the board.

- () Bend the two leads of the capacitor with the correct value at right angles to match their respective holes on the board. Insert the capacitor into the holes on the silk-screened side of the board. Be sure to align the positive polarity side with the "+" signs printed on the board.
- () Holding the capacitor in place, turn the board over and bend the two leads slightly outward. Solder the leads to the foil pattern and clip off any excess lead lengths.
- () Install the other electrolytic capacitors in the same manner.

Crystal Installation

There is one 2.000MHz crystal to be installed on the 8800 CPU Board.

- () Referring to the drawing below, cut a piece of the cardboard container that the crystal is packaged in to the same length as the crystal case itself.

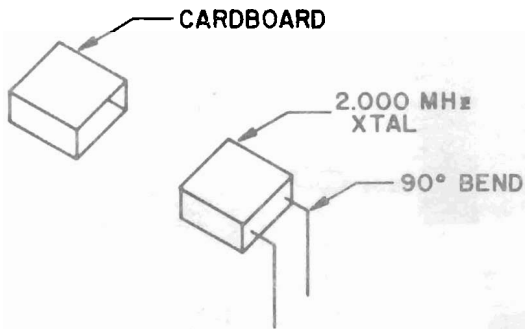

- () Using needle-nose pliers, bend the two leads of the crystal at right angles as in the drawing above.
- () Insert the crystal into the correct holes from the silk-screened side of the board. (see component layout)
- () Holding the crystal in place, turn the board over and bend the two leads slightly outward.
- () Solder the leads to the foil pattern on the back side of the board; then clip off any excess lead lengths.
- () Place the piece of cardboard over the crystal case as indicated in the drawing.

Zener Diode Installation

There is one 5.1 volt and one 12 volt zener diode to be installed on the 8800 CPU Board.

NOTE: Diodes are marked with a band on one end indicating the cathode end. The diode must be oriented so that the end with the band is towards the band printed on the board when being installed.

- () Referring to the component layout, bend the leads on the 12 volt zener at right angles to match the correct holes on the board.
- () Insert the diode into the correct holes from the silk-screened side of the board. Turn the board over and bend the two leads slightly outward.
- () Solder the two leads to the foil pattern on the back side of the board; then clip off any excess lead lengths.
- () Install the 5.1 volt zener diode in the same manner.

Be sure that you have the band on the diode aligned with the band printed on the board for both diodes before proceeding. Failure to orient these two diodes correctly may result in permanent damage to your unit.

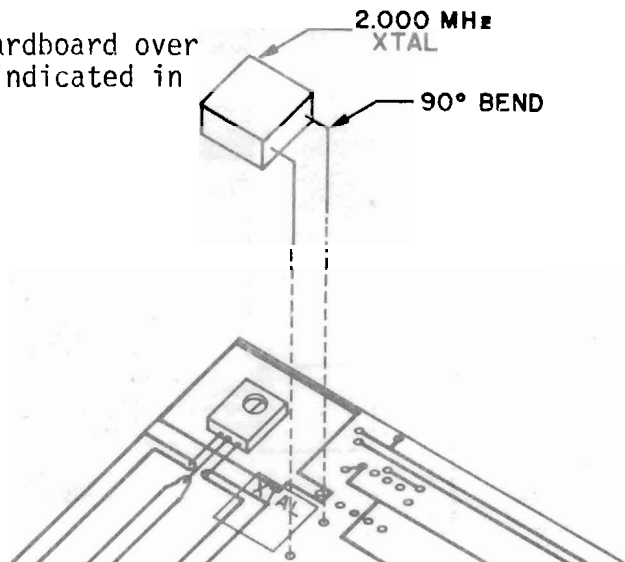

- () XTAL is a 2.00MHz crystal.
- () D1 is a 12v zener diode.
- () D2 is a 5.1v zener diode.

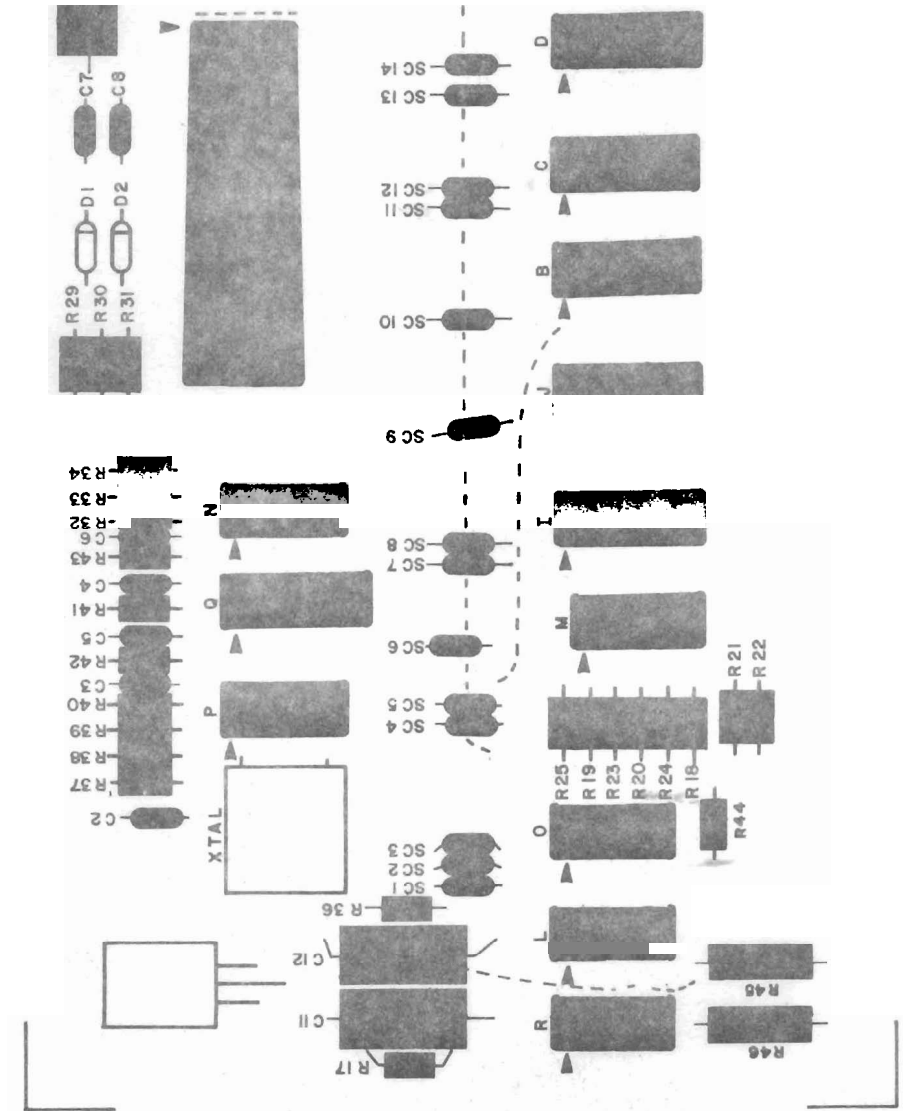
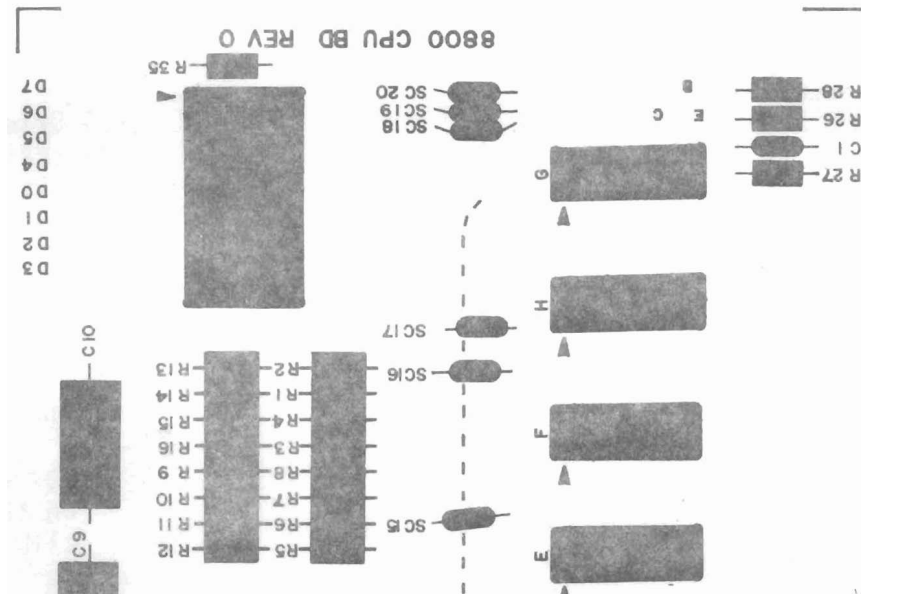

Transistor Installation

There is one CS4410 NPN transistor to be installed on the 8800 CPU Board.

NOTE: When installing this transistor, ensure that you check the part number on it before soldering it into place. Some transistors are identical in physical appearance but differ in electrical characteristics. If the part numbers of your transistors do not match the numbers called for in the instructions, it may be that you have substitutions. In this case, refer to the Transistor Identification Chart included with your manual.

- () This transistor is rounded and has a flat edge near one of the leads. The lead nearest this flat edge is called the emitter. The hole for the emitter is marked with an "E" on the board. If the emitter lead is placed into this hole, the other two leads should fit into their holes with little or no bending and should not cross over each other. (see drawing below)

- () Orient transistor Q1 (CS4410) so that the lead nearest the flat edge aligns with the hole marked "E" on the board. Insert the transistor into the holes from the silk-screened side of the board.
- () Holding the transistor in place, turn the board over and bend the three leads slightly outward.
- () Solder the leads to the foil pattern on the back side of the board; then clip off any excess lead lengths.

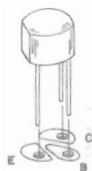
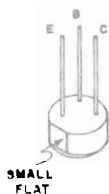

Voltage Regulator Installation

There is one MC7805 5-volt regulator to be installed on the 8800 CPU Board.

- () Set the MC7805 in place on the board and align the mounting holes. (see drawing)
- () Use a pencil to mark the point on each of the three leads where they line up with their respective holes on the board.
- () Use needle-nose pliers to bend each of the three leads at a right angle on the points where you made the pencil marks.

NOTE: Use heat-sink grease when installing this component. Apply the grease to all surfaces which come in contact with each other.

- () Referring to the drawing, set the regulator and heat sink in place on the silk-screened side of the board. Secure them to the board using a #6-32 nut. Hold the regulator in place as you tighten the nut to keep from twisting the leads.
- () Turn the board over and solder the three leads to the foil pattern on the back side of the board. Be sure not to leave any solder bridges.
- () Clip off any excess lead lengths.

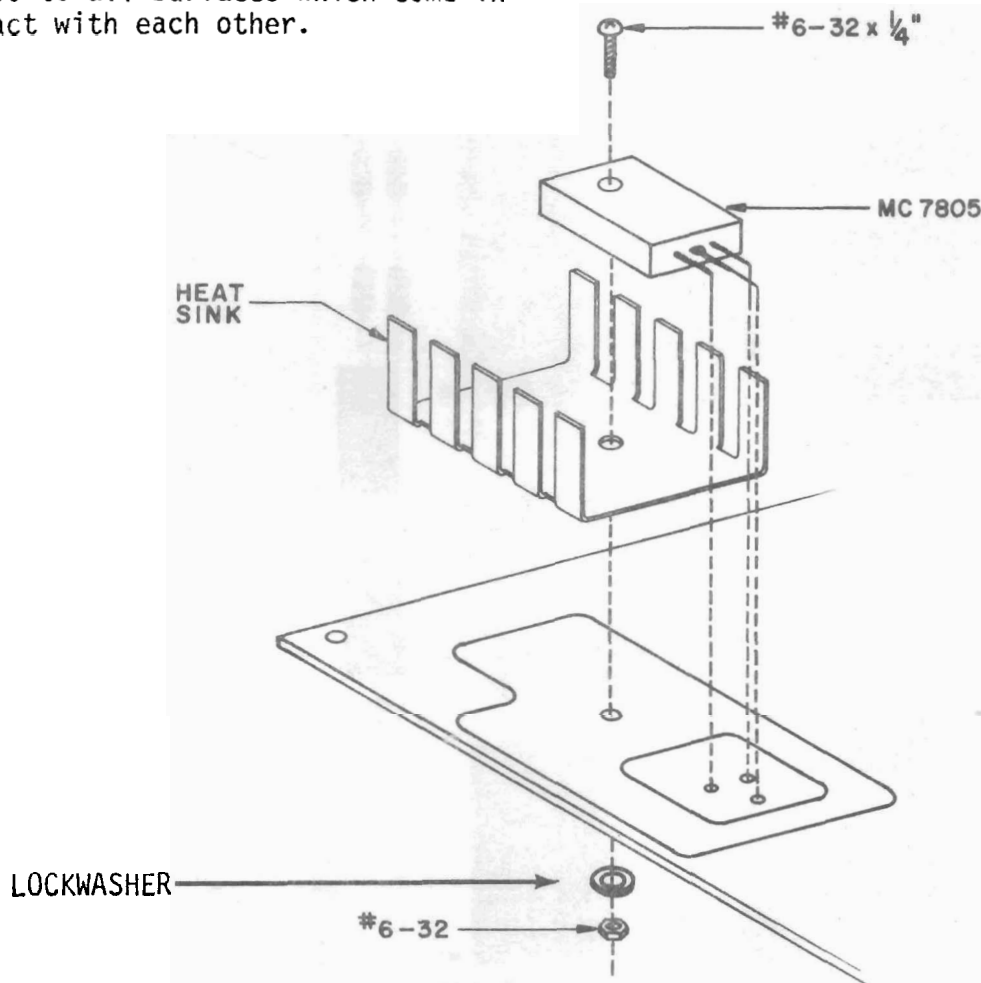

Wafer Connector Installation

There is one 8-pin male connector to be installed on the 8800 CPU Board.

- () Referring to the drawing below, insert the 8-pin wafer connector into the correct holes on the board from the silk-screened side. Be sure to insert the side with the shorter pins.
- () Holding the connector in place, turn the board over and solder the 8 pins to the foil pattern on the back side of the board.

